

36 607 707 Produktversion bis 14.10.2020



- Rosette 60 x 60 mm
- mit Warmkennzeichnung
- Oberteil mit ablängbarer Spindel und Hülse

	Dark Platinum gebürstet	36 607 707-99
	Chrom	36 607 707-00
	Platin gebürstet	36 607 707-06
	Dark Brass matt	36 607 707-16
	Dark Bronze matt	36 607 707-17
	Dark Chrome	36 607 707-19
	Champagne gebürstet (22kt Gold)	36 607 707-46
	Champagne (22kt Gold)	36 607 707-47

**Benötigtes Zubehör**



- UP-Ventil 1/2" -** 35 607 970 90
- Min. Einbautiefe 105 mm
  - Max. Einbautiefe 150 mm

36 607 707 Produktversion bis 14.10.2020

mm [inches]

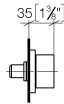
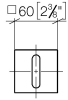

**Codes & Standards**

ASME A112.18.1	cUPC	DIN 4109	EN 200
ISO 3822	Scottish Water Byelaws	UK Water Supply Regulations	Ü-Zeichen

**Zertifikate**

DVGW_DW-6501DN0	LGA_29	WRAS_2010	LGA_29	IAPMO_4976 (
-----------------	--------	-----------	--------	--------------

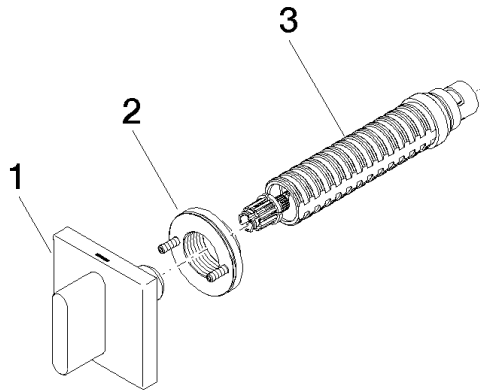

**Ersatzteilstückliste**

Nr.	Artikelnummer	Benennung	Verbaumenge	Lieferzeit
3	90 90 03 142 00 90	Oberteil , linksschließend 1/2" -	1,00	2
1	90 20 70 051 03-99	Griff für Unterputz Wand Hot oval pur 60 x 60 x 40 mm - Dark Platinum gebürstet	1,00	20
2	90 21 02 108 00 90	Wandscheibe komplett -	1,00	2